

MICRO-BUBBLE FLOTATION

DAF-NIKUNI FLOTATORS

DAF-NIKUNI FLOTATORS – The new generation of flotators that use regenerative turbine pump to generate so called micro-air-bubbles of the size 20÷30 µm (traditional flotators 200 – 300 µm), to removal of suspended solids, oils and greases, and other impurities from water slurries.

Tiny air bubbles dissolved in water, uses their exceptional, unprecedented force to interact with the particles floating them to the surface of flotators, where as a skimmed layer is easy to separate. The centre of flotation unit is a reliable DAF-NIKUNI pump.

DAF-NIKUNI, pump eliminates the need for a compressor large size dissolving tank, pressurization tank, agitator, static mixer and other ancillary equipment. It permits for equipment downsizing, reducing processing space requirements, system simplification and substantial cost reduction.

Flotation with DAF-NIKUNI unit, it is a constructional light system designed and elaborated by INWATEC. It is built from highly chemical resistible materials like HDPE, PP, PCV, SS.

Great volume of micro-air-bubbles, up to 8% of water capacity, leads to much better efficiency and productivity, compares to traditional systems.

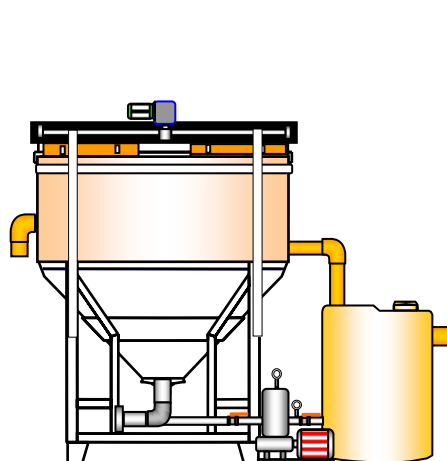

TYPE 10F

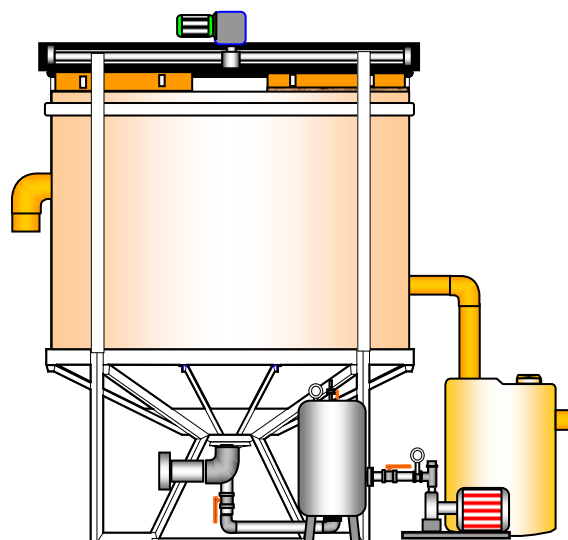

Type	Efficiency [m3/h]	Length [m]	Width [m]	Height [m]	Tank capacity [m3]	Pump efficiency [m3/h]	Electric power. [kW]
10F	10	~2,0	~2,0	~2,5	1,2 ÷ 1,4	1,57 ÷ 3,0	2,2
50F	20 ÷ 50	~3,4	~3,1	÷3,4	5,0 ÷ 7,0	5,0 ÷ 12,0	3,7 ÷ 7,5

CHARACTERISTIC OF DAF-NIKUNI FLOTATION UNIT:

- better efficiency of purification ,
- possibility to remove difficult suspension solids
- high removal of: BOD5, COD, suspension, nitrogen and phosphorus ,
- good sludge dewatering,
- high chemical resistance
- low chemicals demands and consumption,
- low energy demands and consumption,
- low space requirements,
- low noise operation,
- lower performance cost .

DAF-NIKUNI AGAINST TRADITIONAL FLOTATION SYSTEM

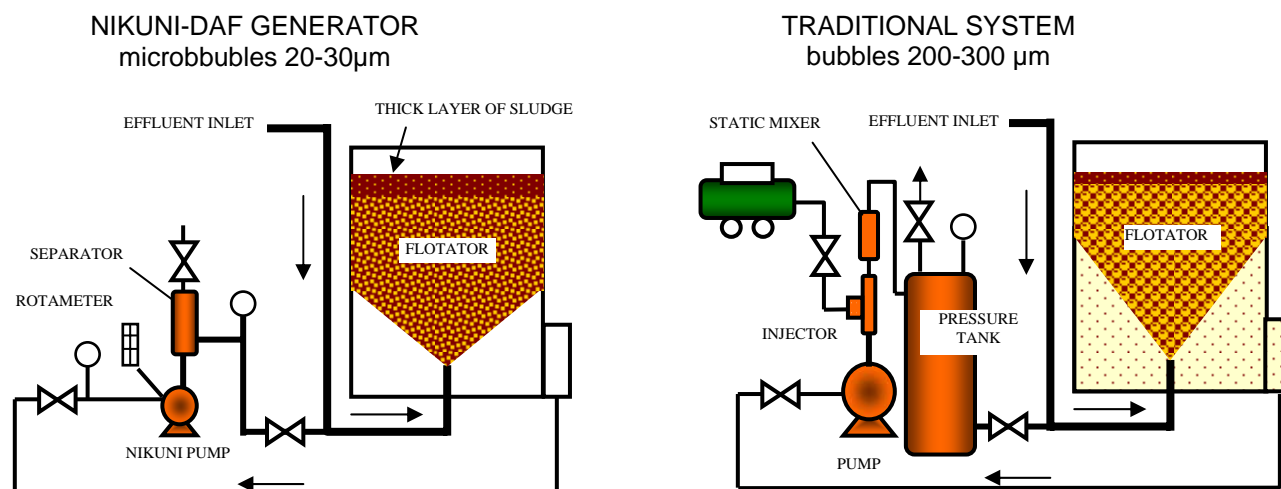

NIKUNI-DAF pump replace complex, traditional system (turbine, air compressor injector, static mixer, big pressure tank) of generating water-air fluid for flotation process

NIKUNI-DAF is a single stage design pump.

Listed below 3 processes perform at the same time

- suction of water and air,
- mixing - dissolving of air and saturation of water
- pumping of saturated water to flotation tank



EFFICIENCY OF DAF-NIKUNI FLOTATION

Nikuni-DAF pump type NPD

Parameter	Unit	Raw sewage	Traditional flotation		DAF-NIKUNI flotation	
			Value	Reduction	Value	Reduction
COD	mg/l	820	280	65,9%	180	78,0%
BOD5	mg/l	520	160	69,2%	100	80,8%
Suspension general	mg/l	1120	150	86,6%	21	98,1%
FOG	mg/l	35	27	22,9%	4,0	88,6%

IF ASSEMBLE NIKUNI-DAF UNIT ON TRADITIONAL FLOTATOR

Parameter	Traditional flotation	DAF-NIKUNI flotation
Efficiency	52 m ³ /h	89 m ³ /h
Suspension general /outlet/	170 mg/l	120 mg/l
Transparency of sewage	68÷72%	79÷82%
Coagulant demands		less than 35%
Polymer demands		less than 40%
Energy demands	16,8 kW	7,6 kW
Suspended solids concentration	1,8 ÷ 2,4%	3,4÷4,0%
Energy consumption		less than 50%